

User Manual

18Gbps HDBaseT Extender(150m) with KVM Function



Manual No: V1.0



Thank you for purchasing this product

For optimum performance and safety, please read these instructions carefully before connecting, operating or adjusting this product. Please keep this manual for future reference.

Surge protection device recommended

This product contains sensitive electrical components that may be damaged by electrical spikes, surges, electric shock, lighting strikes, etc. Use of surge protection systems is highly recommended in order to protect and extend the life of your equipment.

Table of Contents

1. Introduction	- 1 -
2. Features	- 1 -
3. Package Contents	- 2 -
4. Specifications	- 2 -
5. Operation Controls and Functions	- 4 -
5.1 Transmitter Panel	- 4 -
5.2 Receiver Panel	- 5 -
5.3 IR Pin Definition	- 6 -
6. Application Example	- 7 -

1. Introduction

This 18Gbps HDBaseT Extender can extend HDMI signal, bi-directional IR control signal and USB KVM signal to a distance up to 150m via a single CAT6 cable. This product converts HDMI signal to standard HDBaseT signal and transmits it through LAN cable. It can easily control signal source device or display device from the remote end through bi-directional IR signal pass-through function, Video resolution up to 4K2K@60Hz YUV 4:4:4. It also supports USB KVM and POC function.

The extender can be widely used in other fields such as video conference system, multimedia signal broadcasting, HDMI signal extension, etc.

2. Features

- ✧ HDMI2.0b, HDCP 2.2 and USB 1.1 compliant
- ✧ Support 18Gbps video bandwidth
- ✧ Support video resolution up to 4K2K@60Hz YUV 4:4:4
- ✧ The transmission distance can be extended up to 492ft / 150m at the resolution of 1080P@60Hz, or 394ft /120m at 42K@60Hz 4:4:4 via a single CAT6 cable
- ✧ Support bi-directional IR signal and USB KVM signal pass-through
- ✧ Support bi-directional POC (Power over Cable) function
- ✧ Compact design for easy and flexible installation

3. Package Contents

- 1 x 18Gbps HDBaseT Extender (Transmitter)
- 1 x 18Gbps HDBaseT Extender (Receiver)
- 1 x IR Blaster cable (1.5 meters)
- 1 x IR Receiver cable (1.5 meters)
- 1 x USB cable (1.5 meters)
- 4 x Mounting Ears
- 8 x Machine Screws (KM3*4)
- 1x 24V/1A Locking Power Supply
- 1x User Manual

4. Specifications

Technical	
HDMI Compliance	HDMI2.0b
HDCP Compliance	HDCP 2.2
Video Bandwidth	18Gbps
Video Resolution	Up to 4K2K@60Hz YUV 4:4:4
USB Compliance	USB 1.1
IR Level	5Vp-p
IR Frequency	Wideband 20K-60KHz
Transmission Distance	1080P@60--150m, 4K60--120m
Color Space	RGB, YCbCr_4:4:4, YCbCr_4:2:2
Color Depth	8-bit, 10-bit, 12-bit (1080P@60Hz) 8-bit (4K2K@60HZ YUV4:4:4) 8-bit, 10-bit, 12-bit (4K2K@30Hz)
HDR	HDR, HDR10, HDR10+, Dolby Vision, HLG
Audio Format	LPCM 7.1CH, Dolby True HD, and DTS-HD Master
ESD Protection	Human body model---±8kV (Air-gap discharge) &±4kV(Contact discharge)

Connection	
Transmitter	Input: 1xHDMI IN [Type A,19-pin female] 1xIR IN [35mm Stereo Mini-jack] 1xSERVICE [Micro-USB jack] 1xUSB [USB-B, 4-pin female] Output: 1xHDBT OUT[RJ45] 1xIR OUT [3.5mm Stereo Mini-jack]
Receiver	Input: 1xHDBT IN [RJ45 with light] 1xIR IN [3.5mm Stereo Mini-jack] 1xSERVICE [Micro-USB jack] Output: 1xHDMI OUT [Type A, 19-pin female] 1xIR OUT [3.5mm Stereo Mini-jack] 2xUSB [USB-A, 4-pin female]
Mechanical	
Housing	Metal Enclosure
Color	Black
Dimensions	Transmitter/ Receiver:140mm (W)x65mm(D)x18mm(H)
Weight	Transmitter: 246g, Receiver: 246g
Power Supply	DC 24V/1A; Support POC function
Power Consumption	10W
Operating Temperature	0°C-40°C/32°F~104°F
Storage Temperature	-20°C~60°C/-4°F~140°F
Relative Humidity	20~90% RH(non-condensing)

5. Operation Controls and Functions

5.1 Transmitter Panel

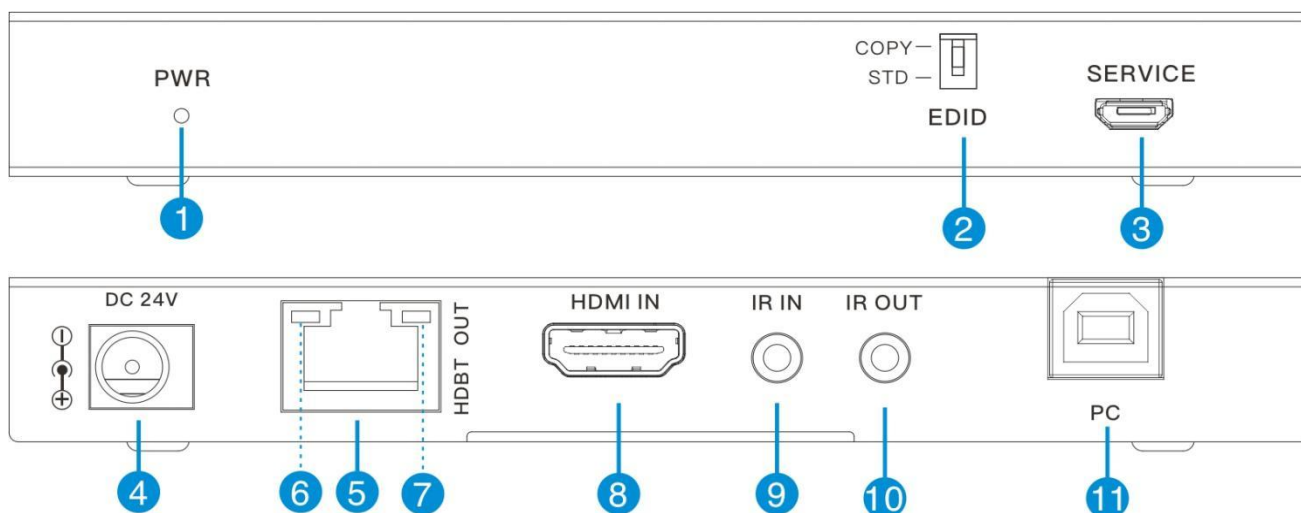

No.	Name	Function Description
1	PWR LED	The red LED is on when the Transmitter is powered on.
2	EDID DIP switch	Used for EDID setting (dial to COPY by default). COPY: Copy the EDID of the HDMI OUT port of Receiver. STD: Default 1080P 2CH
3	SERVICE	Firmware update port
4	DC 24V	DC 24V/1A power input port. <i>Note that the extender supports POC function, it means that either Transmitter or Receiver is connected to 24V/1A power supply, the other doesn't need power supply.</i>
5	HDBT OUT	HDBT output port, connecting to the HDBT IN port of the Receiver with CAT6 cable
6	Link Signal Indicator (Green)	Illuminating: Transmitter and Receiver are in good connection status. Flashing: Transmitter and Receiver are in poor connection status. Dark: Transmitter and Receiver are not connected
7	Data Signal Indicator (Yellow)	Illuminating: HDMI signal with HDCP Flashing: HDMI signal without HDCP Dark: No HDMI signal.
8	HDMI IN	HDMI signal input port, connecting to HDMI source device such as DVD play or Set Top Box.
9	IR IN	Connect to IR receiver cable, the IR receive signal will emit to the IR OUT port of the Receiver.
10	IR OUT	Connect to IR blaster cable, the IR emit signal is from the IR IN port of the Receiver.
11	PC	USB-B port, connecting to PC

5.2 Receiver Panel

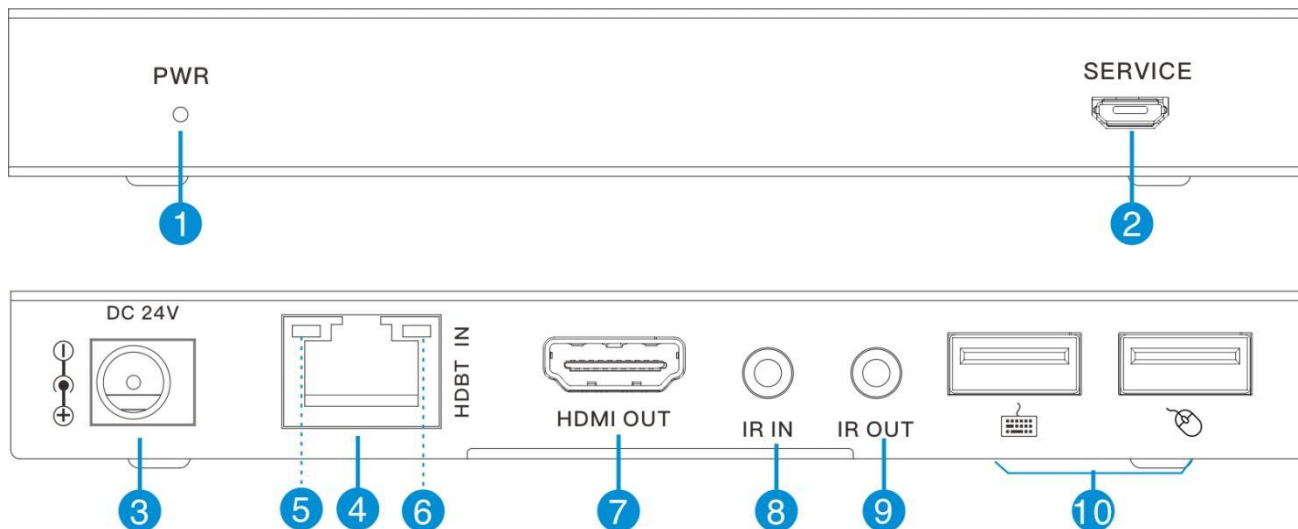

No.	Name	Function Description
1	PWR LED	The power LED is on when the Receiver is powered on.
2	SERVICE	Firmware update port
3	DC 24V	DC 24V/1A power input port. <i>Note that the extender supports POC function, it means that either Transmitter or Receiver is connected to 24V/1A power supply, the other doesn't need power supply.</i>
4	HDBT IN	HDBT input port, connecting to the HDBT OUT port of Transmitter with CAT6 cable.
5	Link Signal Indicator (Green)	Illuminating: Transmitter and Receiver are in good connection status. Flashing: Transmitter and Receiver are in poor connection status. Dark: Transmitter and Receiver are not connected
6	Data Signal Indicator (Yellow)	Illuminating: HDMI signal with HDCP Flashing: HDMI signal without HDCP Dark: No HDMI signal.
7	HDMI OUT	HDMI signal output port, connecting to HDMI display device such as TV or monitor.
8	IR IN	Connect to the IR receiver cable. The IR signal will send to the IR OUT port of the Transmitter.
9	IR OUT	Connect to the IR blaster cable, the IR signal is from IR IN port of the Transmitter.
10	USB ports	Two USB-A ports, connecting to keyboard and mouse respectively.

5.3 IR Pin Definition

IR Receiver and Blaster pin's definition is as below:



IR RECEIVER



IR BLASTER

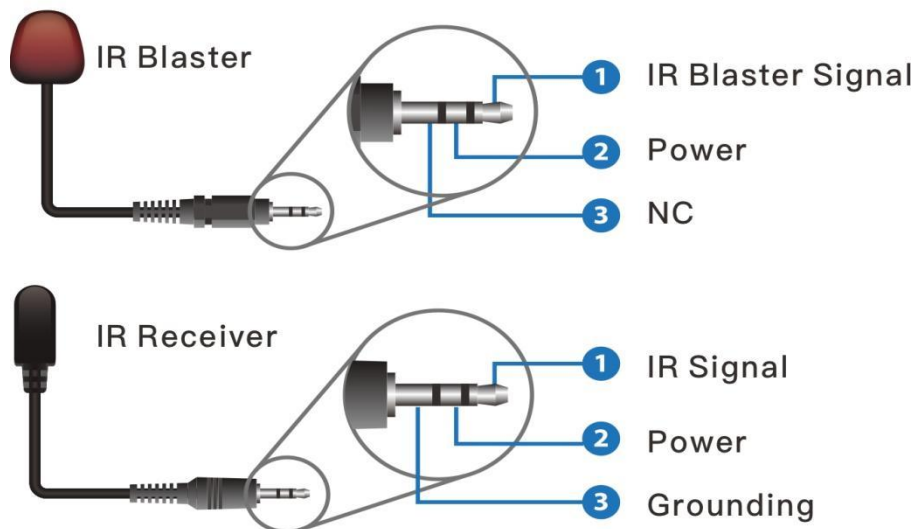

Note:

When the angle between the IR receiver and the remote control is $\pm 45^\circ$, the transmission distance is 0-5 meters;

When the angle between the IR receiver and the remote control is $\pm 90^\circ$, the transmission distance is 0-8 meters.

6. Application Example

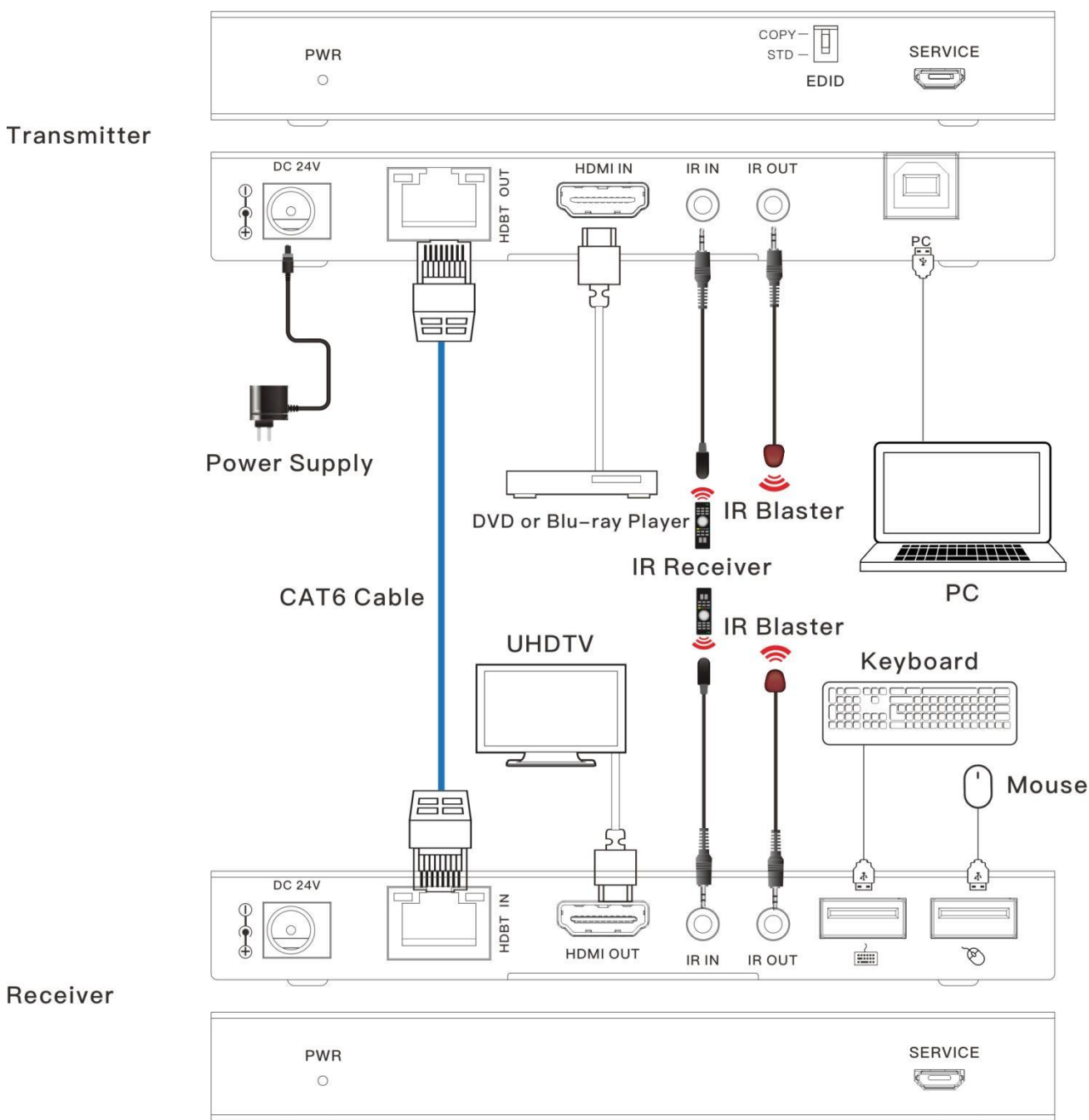

The terms HDMI and HDMI High-Definition Multimedia interface, and the HDMI Logo are trademarks or registered trademarks of HDMI Licensing LLC in the United States and other countries.